



KIRBY® CENTURION

Condensing Units

Smart all-in-one solution
for commercial applications



Exclusively distributed by

KIRBY
A BEIJER REF Company

KIRBY® Centurion Condensing Units

Introduction and Overview

Kirby® Centurion condensing units provide an all-in-one solution for the commercial refrigeration and air conditioning sectors that require larger capacity systems.

This innovative design offers the benefits of faster installation time and energy efficiencies gained from advanced technology within the compressor and air cooled condenser.

Suitable for retail, convenience, cold storage and industrial storage, the Kirby® Centurion range is built on a compact and highly flexible platform; showcasing Kirby's expertise in providing efficiency, environmentally friendly and reliable cooling solutions for a variety of applications.

Features & Benefits

Kirby® Centurion condensing units offer:

- High COP Dorin® H-Series Semi-Hermetic compressors.
- High efficiency remote condenser with optimised coil design and Kirby® Blue Koted fins.
- Factory pre-wired for faster installation and assured performance.
- Factory fitted accumulator and TraxOil*.
- Ease of serviceability made possible by multiple removable access panels.
- Compact footprint ensures suitability for most installations in an outdoor environment especially where floor space is at a minimum.

Kirby® Centurion condensing units can be configured with the following options:

- Head cooling fan
- Accumulator**
- TraxOil**
- Variable speed drive
- Capacity control solenoid valve
- 100 Litre receiver**
- EC Condenser Fans

* 3 Fan models only ** 4 and 6 Fan models only

Kirby® Centurion Condensing Units – Nomenclature

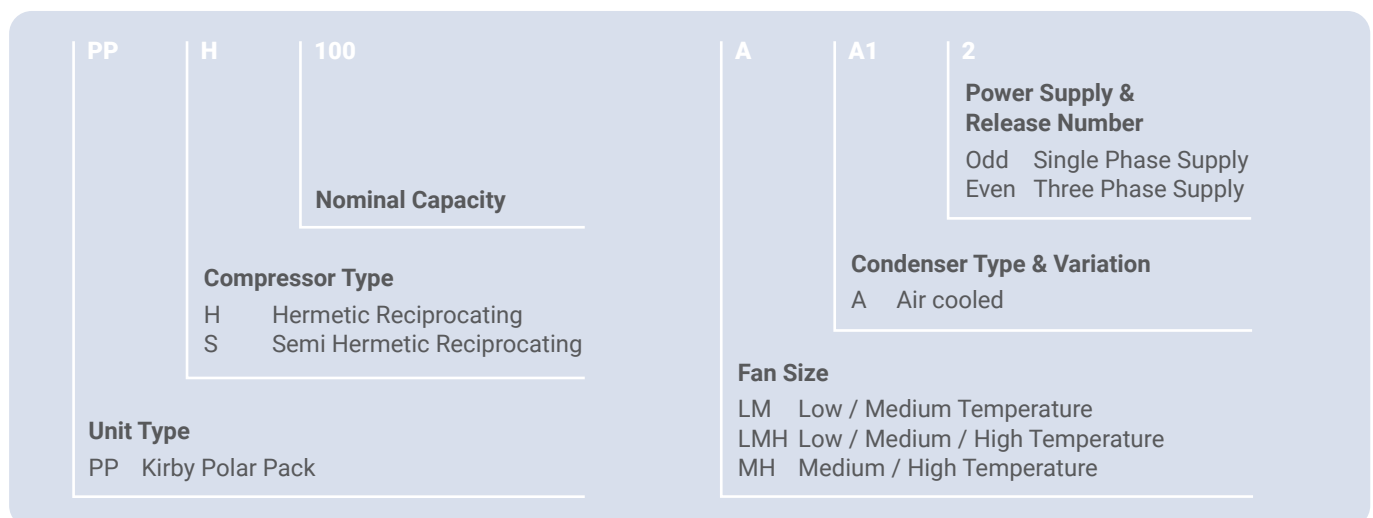

CENTURION CONDENSING UNITS

R404A Performance Data

MODEL	DISPLACEMENT (M3/HR)	AMBIENT TEMPERATURE (°C)	CAPACITY WATTS @ SST (°C)												RECEIVER CAPACITY (KG)
			LT						MT			HT			
			-45	-40	-35	-30	-25	-20	-15	-10	-5	0	5	10	
LOW / MEDIUM TEMPERATURE - DORIN SEMI-HERMETIC RECIPROCATING COMPRESSORS (CS)															
PPS421LMA1-4	63.76	35	-	-	11,470	14,860	18,765	23,225	28,260	33,875	40,045	-	-	-	37.6
		45	-	-	-	11,885	15,195	18,980	23,255	27,990	33,115	-	-	-	
PPS477LMA1-4	75.83	35	-	-	12,395	16,315	20,785	25,865	31,570	37,875	44,710	-	-	-	37.6
		45	-	-	-	13,040	16,830	21,125	25,925	31,175	36,750	-	-	-	
PPS543LMA1-2	85.01	35	-	-	13,790	18,270	23,460	29,400	36,110	43,590	51,800	-	-	-	64.7
		45	-	-	-	14,640	18,990	24,000	29,700	36,010	42,790	-	-	-	
PPS740LMA1-2	113.74	35	-	-	-	24,490	31,260	39,030	47,860	57,720	68,560	-	-	-	64.7
		45	-	-	-	-	25,220	31,840	39,360	47,810	57,050	-	-	-	
PPS803LMA1-2	127.52	35	-	-	20,340	26,730	34,150	42,670	52,330	63,130	75,030	-	-	-	64.7
		45	-	-	-	21,180	27,470	34,700	42,950	52,160	62,140	-	-	-	
PPS950LMA1-2	153.52	35	-	-	25,250	32,620	41,070	50,710	61,580	73,650	86,810	-	-	-	64.7
		45	-	-	-	26,360	33,560	41,740	50,930	61,030	71,830	-	-	-	
LOW / MEDIUM / HIGH TEMPERATURE - DORIN SEMI-HERMETIC RECIPROCATING COMPRESSORS (CC)															
PPS332LMHA1-4	48.82	35	-	-	8,660	11,225	14,160	17,535	21,405	25,775	30,630	35,915	41,520	-	37.6
		45	-	-	6,755	8,930	11,410	14,260	17,520	21,185	25,205	29,495	33,900	-	
PPS491LMHA1-2	75.83	35	-	-	-	16,110	20,810	26,210	32,360	39,270	46,950	55,350	64,390	-	64.7
		45	-	-	-	-	16,770	21,350	26,550	32,400	38,830	45,750	52,970	-	
PPS551LMHA1-2	85.01	35	-	-	13,290	17,760	22,900	28,830	35,600	43,230	51,690	60,880	70,630	-	64.7
		45	-	-	-	14,010	18,380	23,420	29,160	35,590	42,630	50,120	57,790	-	
PPS747LMHA1-2	113.74	35	-	-	-	24,310	30,930	38,600	47,400	57,360	68,460	80,650	93,810	-	64.7
		45	-	-	-	-	25,080	31,600	39,090	47,560	56,940	67,070	77,690	-	
PPS825LMHA1-2	127.52	35	-	-	20,860	27,210	34,530	42,950	52,550	63,360	75,370	88,480	102,490	-	64.7
		45	-	-	-	21,760	28,010	35,200	43,390	52,580	62,660	73,400	84,450	-	

- Liquid entering temperature with inherent sub-cooling average 2-3°C, return vapour temperature of 20°C. Return vapour temperature should never exceed 20°C for any refrigerant.
- Low temperature applications should be restricted to 20K return vapour superheat.
- All capacity data based on continuous condenser fan operation without the consideration of fan speed control.



CENTURION CONDENSING UNITS

R134a Performance Data

MODEL	DISPLACEMENT (M3/HR)	AMBIENT TEMPERATURE (°C)	CAPACITY WATTS @ SST (°C)												RECEIVER CAPACITY (KG)
			LT						MT			HT			
			-45	-40	-35	-30	-25	-20	-15	-10	-5	0	5	10	
LOW / MEDIUM / HIGH TEMPERATURE - DORIN SEMI-HERMETIC RECIPROCATING COMPRESSORS (CC)															
PPS332LMHA1-4	48.82	35	-	-	-	-	-	8,990	11,780	15,050	18,850	23,240	28,220	33,790	43.7
		45	-	-	-	-	-	-	10,010	12,960	16,390	20,330	24,780	29,750	
LOW / MEDIUM TEMPERATURE - DORIN SEMI-HERMETIC RECIPROCATING COMPRESSORS (CS)															
PPS421LMA1-4	63.76	35	-	-	-	-	-	12,100	15,630	19,760	24,550	30,040	36,220	43,060	43.7
		45	-	-	-	-	-	-	13,290	17,020	21,360	26,300	31,850	37,980	
PPS477LMA1-4	75.83	35	-	-	-	-	-	15,790	20,355	25,610	31,590	38,275	45,625	53,580	43.7
		45	-	-	-	-	-	-	13,335	17,470	22,225	27,610	33,615	40,200	
PPS543LMA1-2	85.01	35	-	-	-	-	-	17,020	22,010	27,810	34,500	42,120	50,670	60,110	75.3
		45	-	-	-	-	-	-	14,320	18,860	24,120	30,160	37,020	44,690	
PPS803LMA1-2	127.52	35	-	-	-	-	-	25,160	32,610	41,300	51,320	62,750	75,580	89,710	75.3
		45	-	-	-	-	-	-	21,060	27,830	35,690	44,760	55,040	66,540	
PPS950LMA1-2	153.52	35	-	-	-	-	22,380	29,860	38,580	48,710	60,390	73,640	88,410	104,540	75.3
		45	-	-	-	-	-	-	24,880	32,820	42,050	52,650	64,650	78,020	
MEDIUM / HIGH TEMPERATURE - DORIN SEMI-HERMETIC RECIPROCATING COMPRESSORS (CS)															
PPS373MHA1-4	H2500CS	35	-	-	-	-	-	16,710	21,560	27,130	33,470	40,610	48,590	57,390	43.7
		45	-	-	-	-	-	-	14,070	18,470	23,530	29,270	35,720	42,880	
PPS492MHA1-2	113.74	35	-	-	-	-	16,440	21,800	28,030	35,240	43,490	52,810	63,190	74,660	75.3
		45	-	-	-	-	-	-	13,370	18,230	23,860	30,360	37,790	46,150	

- Liquid entering temperature with inherent sub-cooling average 2-3°C, return vapour temperature of 20°C. Return vapour temperature should never exceed 20°C for any refrigerant.
- Low temperature applications should be restricted to 20K return vapour superheat.
- All capacity data based on continuous condenser fan operation without the consideration of fan speed control.

CENTURION CONDENSING UNITS

R407F Performance Data

MODEL	DISPLACEMENT (M3/HR)	AMBIENT TEMPERATURE (°C)	CAPACITY WATTS @ SST (°C)												RECEIVER CAPACITY (KG)
			LT						MT			HT			
			-45	-40	-35	-30	-25	-20	-15	-10	-5	0	5	10	
LOW / MEDIUM TEMPERATURE - DORIN SEMI-HERMETIC RECIPROCATING COMPRESSORS (CS)															
PPS543LMA1-2	85.01	35	-	-	-	14,280	19,460	25,660	32,950	41,390	51,030	-	-	-	69.7
		45	-	-	-	-	15,750	21,250	27,870	35,600	44,350	-	-	-	
PPS740LMA1-2	113.74	35	-	-	-	19,140	25,930	34,070	43,670	54,810	67,550	-	-	-	69.7
		45	-	-	-	-	20,920	28,180	36,940	47,260	59,130	-	-	-	
PPS803LMA1-2	127.52	35	-	-	-	20,890	28,320	37,240	47,740	59,940	73,930	-	-	-	69.7
		45	-	-	-	-	22,780	30,720	40,300	51,560	64,410	-	-	-	
PPS950LMA1-2	153.52	35	-	-	-	25,500	34,070	44,260	56,190	69,940	85,530	-	-	-	69.7
		45	-	-	-	-	27,840	36,960	47,790	60,330	74,450	-	-	-	
LOW / MEDIUM / HIGH TEMPERATURE - DORIN SEMI-HERMETIC RECIPROCATING COMPRESSORS (CC)															
PPS491LMHA1-2	75.83	35	-	-	-	12,290	16,840	22,310	28,810	36,390	45,080	54,890	65,800	-	69.7
		45	-	-	-	-	13,370	18,100	23,880	30,740	38,650	47,520	57,200	-	
PPS551LMHA1-2	85.01	35	-	-	-	13,550	18,530	24,540	31,700	40,060	49,630	60,370	72,180	-	69.7
		45	-	-	-	-	14,650	19,860	26,220	33,770	42,440	52,060	62,410	-	
PPS747LMHA1-2	113.74	35	-	-	-	18,540	25,020	32,870	42,210	53,150	65,730	79,980	95,870	-	69.7
		45	-	-	-	-	19,990	26,800	35,150	45,120	56,680	69,670	83,900	-	
PPS825LMHA1-2	127.52	35	-	-	-	20,760	27,940	36,570	46,790	58,710	72,370	87,750	104,740	-	69.7
		45	-	-	-	-	22,330	29,850	39,020	49,890	62,380	76,250	91,200	-	

- Liquid entering temperature with inherent sub-cooling average 2-3°C, return vapour temperature of 20°C. Return vapour temperature should never exceed 20°C for any refrigerant.
- Low temperature applications should be restricted to 20K return vapour superheat.
- All capacity data based on continuous condenser fan operation without the consideration of fan speed control.

CENTURION CONDENSING UNITS

R448A Performance Data

MODEL	DISPLACEMENT (M3/HR)	AMBIENT TEMPERATURE (°C)	CAPACITY WATTS @ SST (°C)												RECEIVER CAPACITY (KG)
			LT						MT			HT			
			-45	-40	-35	-30	-25	-20	-15	-10	-5	0	5	10	
LOW / MEDIUM TEMPERATURE - DORIN SEMI-HERMETIC RECIPROCATING COMPRESSORS (CS)															
PPS543LMA1-2	85.01	35	-	-	-	15,520	20,410	26,240	33,100	41,100	50,330	-	-	-	60.3
		45	-	-	-	-	16,750	21,780	27,760	34,760	42,750	-	-	-	
PPS740LMA1-2	113.74	35	-	-	-	20,800	27,200	34,840	43,870	54,420	66,630	-	-	-	60.3
		45	-	-	-	-	22,250	28,880	36,800	46,150	57,000	-	-	-	
PPS803LMA1-2	127.52	35	-	-	-	22,700	29,710	38,080	47,970	59,530	72,910	-	-	-	60.3
		45	-	-	-	-	24,230	31,480	40,150	50,350	62,080	-	-	-	
PPS950LMA1-2	153.52	35	-	-	-	27,700	35,740	45,260	56,450	69,450	84,360	-	-	-	60.3
		45	-	-	-	-	29,610	37,870	47,620	58,910	71,760	-	-	-	
LOW / MEDIUM / HIGH TEMPERATURE - DORIN SEMI-HERMETIC RECIPROCATING COMPRESSORS (CC)															
PPS491LMHA1-2	75.83	35	-	-	-	-	18,220	23,460	29,590	36,670	44,790	54,020	64,420	-	60.3
		45	-	-	-	-	-	14,960	19,510	24,850	31,050	38,140	46,120	54,960	
PPS551LMHA1-2	85.01	35	-	-	-	15,180	20,050	25,800	32,550	40,370	49,310	59,420	70,670	-	60.3
		45	-	-	-	-	16,400	21,400	27,290	34,110	41,870	50,530	59,970	-	
PPS747LMHA1-2	113.74	35	-	-	-	-	27,070	34,550	43,350	53,560	65,320	78,720	93,860	-	60.3
		45	-	-	-	-	22,380	28,880	36,580	45,580	55,920	67,610	80,620	-	
PPS825LMHA1-2	127.52	35	-	-	-	23,260	30,230	38,450	48,050	59,170	71,910	86,360	102,550	-	60.3
		45	-	-	-	-	25,000	32,170	40,610	50,390	61,540	74,000	87,630	-	

- Liquid entering temperature with inherent sub-cooling average 2-3°C, return vapour temperature of 20°C. Return vapour temperature should never exceed 20°C for any refrigerant.
- Low temperature applications should be restricted to 20K return vapour superheat.
- All capacity data based on continuous condenser fan operation without the consideration of fan speed control.

CENTURION CONDENSING UNITS

R513A Performance Data

MODEL	DISPLACEMENT (M3/HR)	AMBIENT TEMPERATURE (°C)	CAPACITY WATTS @ SST (°C)												RECEIVER CAPACITY (KG)	
			LT						MT			HT				
			-45	-40	-35	-30	-25	-20	-15	-10	-5	0	5	10		
LOW / MEDIUM TEMPERATURE - DORIN SEMI-HERMETIC RECIPROCATING COMPRESSORS (CS)																
PPS543LMA1-2	85.01	35	-	-	-	-	-	18,230	23,050	28,510	34,710	41,700	49,480	57,960	57.7	
		45	-	-	-	-	-	15,340	19,750	24,730	30,340	36,650	43,640	51,210		
PPS803LMA1-2	127.52	35	-	-	-	-	-	26,950	34,140	42,340	51,630	62,120	73,810	86,510	57.7	
		45	-	-	-	-	-	22,560	29,140	36,590	45,030	54,490	64,980	76,380		
PPS950LMA1-2	153.52	35	-	-	-	-	-	24,570	31,990	40,400	49,930	60,750	72,900	86,340	100,810	57.7
		45	-	-	-	-	-	26,650	34,360	43,110	52,970	64,000	76,190	-		
MEDIUM / HIGH TEMPERATURE - DORIN SEMI-HERMETIC RECIPROCATING COMPRESSORS (CS)																
PPS492MHA1-2	113.74	35	-	-	-	-	-	18,050	23,350	29,350	36,130	43,750	52,280	61,710	71,990	57.7
		45	-	-	-	-	-	14,680	19,530	24,980	31,120	38,020	45,690	54,110	-	

- Liquid entering temperature with inherent sub-cooling average 2-3°C, return vapour temperature of 20°C. Return vapour temperature should never exceed 20°C for any refrigerant.
- Low temperature applications should be restricted to 20K return vapour superheat.
- All capacity data based on continuous condenser fan operation without the consideration of fan speed control.

CENTURION CONDENSING UNITS

R450A Performance Data

MODEL	DISPLACEMENT (M3/HR)	AMBIENT TEMPERATURE (°C)	CAPACITY WATTS @ SST (°C)											RECEIVER CAPACITY (KG)	
			LT					MT			HT				
			-45	-40	-35	-30	-25	-20	-15	-10	-5	0	5		10
LOW / MEDIUM / HIGH TEMPERATURE - DORIN SEMI-HERMETIC RECIPROCATING COMPRESSORS (CC)															
PPS543LMA1-2	85.01	35	-	-	-	-	-	15,020	19,370	24,380	30,180	36,830	44,400	52,900	55.4
		45	-	-	-	-	-	12,640	16,590	21,150	26,380	32,370	39,160	46,740	
PPS803LMA1-2	127.52	35	-	-	-	-	-	22,210	28,690	36,210	44,890	54,870	66,230	78,950	55.4
		45	-	-	-	-	-	18,590	24,490	31,290	39,150	48,130	58,310	69,710	
PPS950LMA1-2	153.52	35	-	-	-	-	19,740	26,360	33,950	42,700	52,820	64,400	77,470	92,000	55.4
		45	-	-	-	-	-	21,960	28,880	36,870	46,050	56,530	68,370	-	
MEDIUM / HIGH TEMPERATURE - DORIN SEMI-HERMETIC RECIPROCATING COMPRESSORS (CS)															
PPS492MHA1-2	113.74	35	-	-	-	-	14,500	19,240	24,660	30,890	38,040	46,180	55,370	65,710	55.4
		45	-	-	-	-	11,790	16,090	20,990	26,620	33,050	40,360	48,550	-	

- Liquid entering temperature with inherent sub-cooling average 2-3°C, return vapour temperature of 20°C. Return vapour temperature should never exceed 20°C for any refrigerant.
- Low temperature applications should be restricted to 20K return vapour superheat.
- All capacity data based on continuous condenser fan operation without the consideration of fan speed control.

CENTURION CONDENSING UNITS

Technical Data

MODEL	COMPRESSOR MODEL	CONDENSER FAN DATA			ELECTRICAL DATA				CONNECTIONS		SOUND POWER DB(A)
		NO. OF FANS	DIAMETER (MM)	AIRFLOW (L/S)	MCC	LRA	RLA	INPUT	SUCTION	LIQUID	
LOW / MEDIUM TEMPERATURE - DORIN SEMI-HERMETIC RECIPROCATING COMPRESSORS (CS)											
PPS421LMA1-4	H1601CS	3	630	5,351	42.0	170.5	38.1	18,690	41.28	22.22	81.0
PPS477LMA1-4	H2000CS	3	630	5,351	46.0	177.0	41.1	21,070	41.28	22.22	79.3
PPS543LMA1-2	H2500CS	4	630	8,030	55.6	213.6	48.4	21,640	53.00	28.00	80.4
PPS740LMA1-2	H3000CS	6	630	12,040	71.9	239.9	64.2	27,460	53.00	28.00	83.0
PPS803LMA1-2	H3500CS	6	630	12,040	71.9	239.9	68.0	27,460	53.00	28.00	83.4
PPS950LMA1-2	H4500CS	6	630	11,240	87.9	305.9	79.0	34,360	53.00	28.00	83.8
LOW / MEDIUM / HIGH TEMPERATURE - DORIN SEMI-HERMETIC RECIPROCATING COMPRESSORS (CC)											
PPS332LMHA1-4	H1501CC	3	630	6,169	42.0	170.5	32.5	14,520	41.28	22.22	79.9
PPS491LMHA1-2	H2500CC	4	630	8,030	58.6	216.6	44.3	22,840	53.00	28.00	79.8
PPS551LMHA1-2	H3000CC	4	630	7,490	66.6	234.6	48.4	26,240	53.00	28.00	80.4
PPS747LMHA1-2	H3500CC	6	630	11,240	75.9	275.9	64.2	29,160	53.00	28.00	83.0
PPS825LMHA1-2	H4000CC	6	630	11,240	87.9	305.9	70.0	34,360	53.00	28.00	83.4
MEDIUM / HIGH TEMPERATURE - DORIN SEMI-HERMETIC RECIPROCATING COMPRESSORS (CS)											
PPS373MHA1-4	H2500CS	3	630	5,351	33.8	203.0	25.6	11,510	41.28	22.22	80.0
PPS492MHA1-2	H3000CS	4	630	7,490	53.1	255.6	42.1	17,810	53.00	28.00	82.6

- Estimated unit input power is calculated from compressor calorimeter data (where available) and fan manufacturers data. It includes approximate fan input power at 100% speed for standard ac fans. Actual power may vary due to power supply variations, system conditions, and fan speed control operation.
- Sound power data is based on 60% fan speed, which corresponds to approximately 35°C condensing running condition.

CENTURION CONDENSING UNITS

Physical Data

MODEL	DIMENSIONS (MM)			MOUNTING HOLE (MM)			WEIGHT (KG)	
	HEIGHT	WIDTH	DEPTH	A	B	C	NET	GROSS
LOW / MEDIUM TEMPERATURE - DORIN SEMI-HERMETIC RECIPROCATING COMPRESSORS (CS)								
PPS421LMA1-4	1,090	1,005	3,300	1,890	1,210	950	560	610
PPS477LMA1-4	1,090	1,005	3,300	1,890	1,210	950	570	620
PPS543LMA1-2	1,270	2,230	2,500	1,504	895	2,180	920	970
PPS740LMA1-2	1,270	2,230	3,240	2,239	895	2,180	1,070	1,120
PPS803LMA1-2	1,270	2,230	3,240	2,239	895	2,180	1,070	1,120
PPS950LMA1-2	1,270	2,230	3,240	2,239	895	2,180	1,090	1,140
LOW / MEDIUM / HIGH TEMPERATURE - DORIN SEMI-HERMETIC RECIPROCATING COMPRESSORS (CC)								
PPS332LMHA1-4	1,090	1,005	3,300	1,890	1,210	950	500	550
PPS491LMHA1-2	1,270	2,230	2,500	1,504	895	2,180	920	970
PPS551LMHA1-2	1,270	2,230	2,500	1,504	895	2,180	920	970
PPS747LMHA1-2	1,270	2,230	3,240	2,239	895	2,180	1,070	1,120
PPS825LMHA1-2	1,270	2,230	3,240	2,239	895	2,180	1,080	1,130
MEDIUM / HIGH TEMPERATURE - DORIN SEMI-HERMETIC RECIPROCATING COMPRESSORS (CS)								
PPS373MHA1-4	1,090	1,005	3,300	1,890	1,210	950	570	620
PPS492MHA1-2	1,270	2,230	2,500	1,504	895	2,180	920	970

3 Fan Models

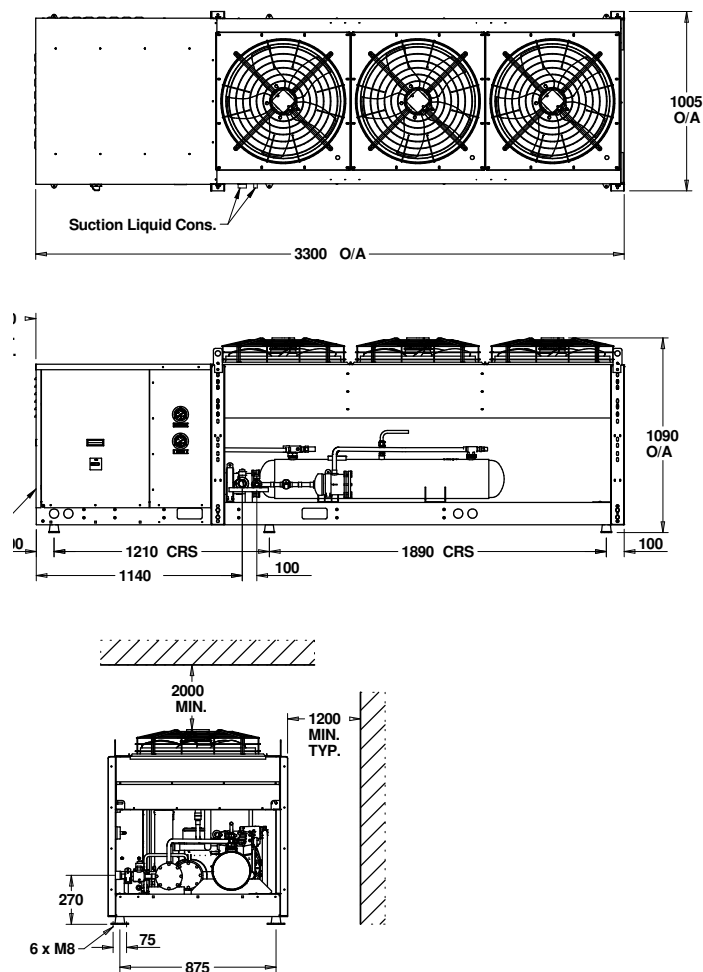

4 Fan Models

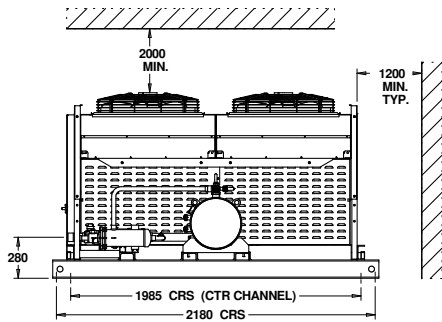
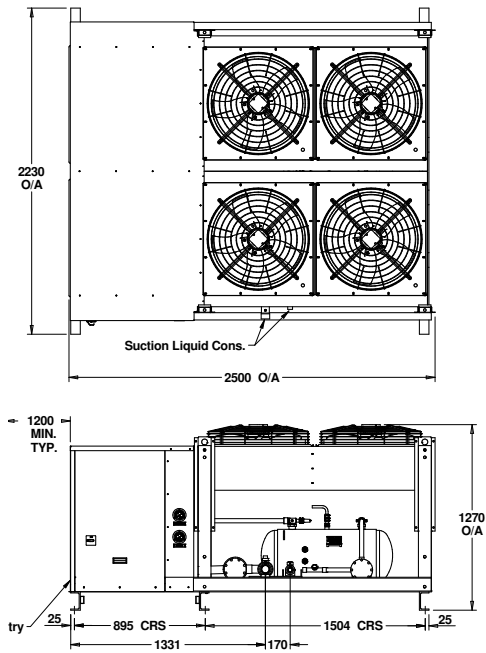

6 Fan Models

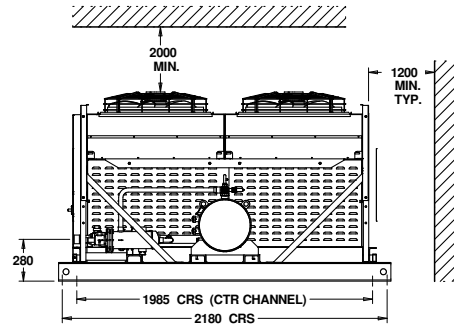
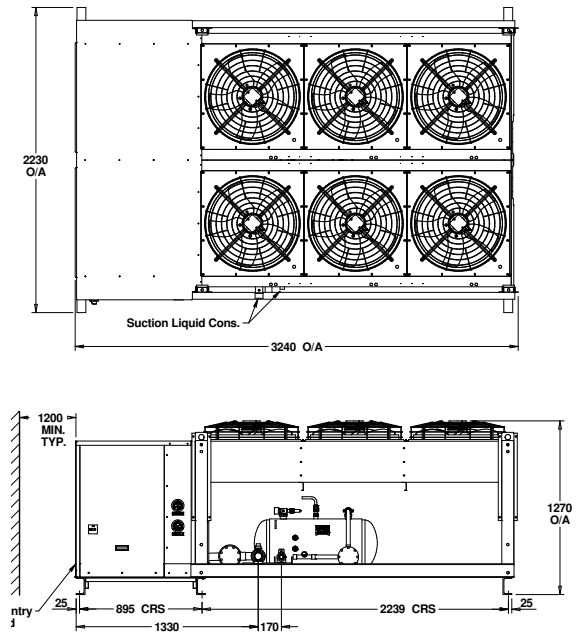

13 23 50
kirbyhvacr.com.au

Exclusively distributed by

KIRBY
A BEIJER REF Company

The contents of this brochure are copyright protected and may not be reproduced in any form without the written consent of Kirby HVAC&R Pty Ltd (T/A Kirby). Recommendations and advice regarding the use of the products described in this publication are to be taken as a guide only and are given without liability on the part of the company or its employees. As Kirby continually improves its product range and processes, Kirby reserves the right to change product specifications without any prior notification. Please refer to the kirbyhvacr.com.au website for the latest version of this publication. The purchaser should independently determine the suitability of the product for the intended use and application and that the product complies with relevant standards. Kirby accepts no responsibility for loss or damage (direct or indirect and including consequential loss, loss of profits or opportunity and economic loss) however arising which results from any errors or omissions in the information contained in this publication or arising from the use or application of the information contained herein.

Kirby HVAC&R Pty Ltd continually strives to improve products and processes. We reserve the right to modify product features without notice. Information is correct at time of printing.

© Copyright 2025 Kirby HVAC&R Pty Ltd
Information is correct at time of printing.